

**CLEVER
HOMES**

START
NIGHT & MORE
BABYSTART

START

CLEVER **START**



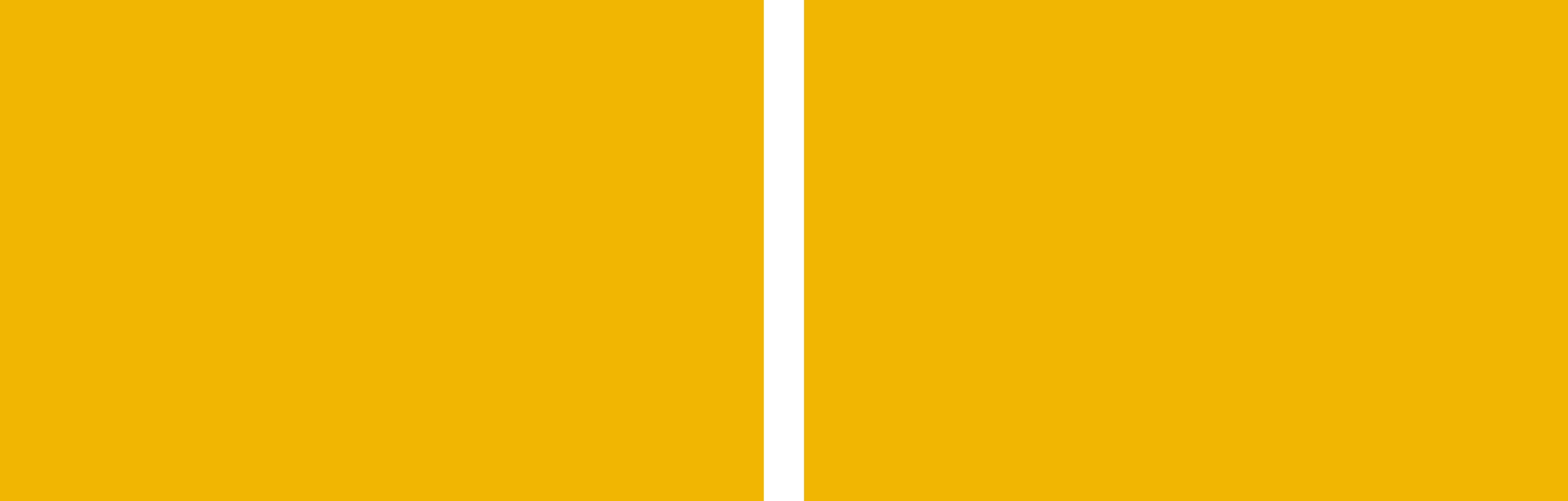

START

UNA SANA VOGLIA DI CRESCERE

A HEALTHY DESIRE TO GROW OLDER - UNE SAINTE ENVIE DE GRANDIR



START

TUTTI I COLORI DEL MONDO

ALL COLOURS OF THE WORLD - TOUTES LES COULEURS DU MONDE



01 **START** PAGE 06

02 **NIGHT&MORE** PAGE 178

03 **BABY START** PAGE 218

04 **INFO** PAGE 242

ECOLOGIA E SALUTE

UNA SANA VOGLIA DI CRESCERE

A HEALTHY DESIRE TO GROW OLDER - UNE SAINTE ENVIE DE GRANDIR

CLEVER È UNA AZIENDA IMPEGNATA NELLA SALVAGUARDIA DELL'AMBIENTE E DELLA SALUTE DELLE PERSONE. PER QUESTO MOTIVO IMPIEGA MATERIALI CON EMISSIONI DI FORMALDEIDE, "COMPOSTO CHIMICO RITENUTO TOSSICO" PROSSIME ALLO ZERO. TUTTI I PANNELLI USATI NELLA PRODUZIONE SONO IN CLASSE EPF-S CON REQUISITI TALI DA SODDISFARE ANCHE LE NORMATIVE PIÙ SEVERE IN FATTO DI EMISSIONI.

LA STESSA SENSIBILITÀ HA SPINTO L'AZIENDA, DA DIVERSI ANNI, AL SOLO UTILIZZO DI VERNICI AD ACQUA CERTIFICATE C.E. SICUREZZA GIOCATTOI, ELIMINANDO COSÌ L'USO DI SOLVENTI CHIMICI. BISOGNA FARE MOLTA ATTENZIONE ALL'AMBIENTE DOVE I BAMBINI DORMONO, GIOCANO E STUDIANO.

CLEVER IS A COMPANY COMMITTED TO SAFEGUARDING THE ENVIRONMENT AND THE HEALTH AND SAFETY OF PEOPLE.

THIS IS WHY CLEVER USES MATERIALS WITH EMISSIONS OF FORMALDEHYDE (A TOXIC CHEMICAL SUBSTANCE) AS CLOSE TO ZERO AS IS TECHNICALLY POSSIBLE.

ALL PANELS USED FOR PRODUCTION BELONG TO CLASS EPF-S AND COMPLY WITH THE MOST STRINGENT NORMS AND REGULATIONS ON EMISSIONS.

FOR MANY YEARS CLEVER HAS BEEN USING EXCLUSIVELY CE-CERTIFIED WATER-BASED PAINTS SUITABLE FOR TOYS, CONTAINING NO CHEMICAL SOLVENTS.

WE NEED TO PAY SPECIAL ATTENTION TO THE ENVIRONMENT WHERE OUR CHILDREN SLEEP, PLAY AND STUDY.

CLEVER EST UNE ENTREPRISE ENGAGÉE DANS LA PROTECTION DE L'ENVIRONNEMENT ET DE LA SANTÉ DES PERSONNES.

POUR CETTE RAISON, ELLE UTILISE DES MATÉRIAUX AVEC DES ÉMISSIONS DE FORMALDÉHYDE; "COMPOSE CHIMIQUE ESTIME TOXIQUE" PROCHES DE ZÉRO. TOUS LES PANNEAUX UTILISÉS DANS LA PRODUCTION SONT DE CLASSE EPF-S AVEC DES CONDITIONS REQUISES EN MESURE DE SATISFAIRE ÉGALEMENT LES RÉGLEMENTATIONS LES PLUS SÉVÈRES EN MATIÈRE D'ÉMISSIONS.

CETTE SENSIBILITÉ A INCITÉ L'ENTREPRISE, DEPUIS PLUSIEURS ANNÉES, A L'UTILISATION SEULE DE VERNIS A EAU CERTIFIÉS C.E. SÉCURITÉ JOUETS, ÉLIMINANT AINSI L'UTILISATION DE SOLVANTS CHIMIQUES. IL FAUT FAIRE TRÈS ATTENTION À L'AMBIANCE DANS LAQUELLE LES ENFANTS DORMENT, JOUENT ET FONT LEURS DEVOIRS.



01 START

L'EVOLUZIONE DELLO SPAZIO. | THE EVOLUTION OF SPACE. | L'ÉVOLUTION DE L'ESPACE.



CLEVER START CAMERETTE PER RAGAZZI | TEEN BEDROOMS | CHAMBRES D'ADOLESCENTS







Il letto Lully è stampato in polipropilene, materiale resistente e facilmente lavabile.

The Lully bed is in moulded polypropylene, a resistant and easy-to-wash material.

Le lit Lully est moulé en polypropylène, un matériau solide et facile à laver.







Armadiatura pensile, libreria con piano lavoro a ribalta; letto Lully con led luminoso; contenitore su ruote Round; casellari a parete Home.

Finiture: melaminico Bianco; laccato Antracite e Melanzana.

Suspended wardrobe, bookcase with flap desk; Lully bed with LED; Round cabinet on wheels; Home wall shelving units.

Finishes: White melamine; lacquers Anthracite and Aubergine.

Système d'armoire haute, bibliothèque avec plan de travail rabattable; lit Lully avec led lumineux; élément de rangement sur roues Round; casiers muraux Home.

Finitions: Blanc mélaminé; laqués Anthracite et Aubergine.

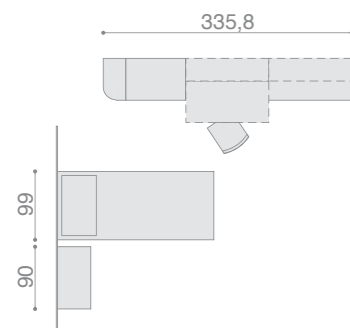





Armadio ante scorrevoli **Puzzle**;
scrivitoio scorrevole con gamba
Diapason; letto **Karta** con contenitore e pannelli tessili; casellario **Cross**; sedia **Harmony**.
Finiture: melaminico Bianco; laccato Lilla e Verde Acido.

Puzzle wardrobe with sliding doors;
sliding desk with **Diapason** leg;
Karta bed with storage space and fabric panels; **Cross** shelving unit; **Harmony** chair.
Finishes: White melamine; lacquers Lilac and Acid Green.

Armoire portes coulissantes **Puzzle**;
bureau coulissant sur pied **Diapason**;
lit **Karta** avec élément de rangement et panneaux textiles; Casier **Cross**; chaise **Harmony**.
Finitions: Blanc mélaminé; laqués Mauve et Vert Acide.

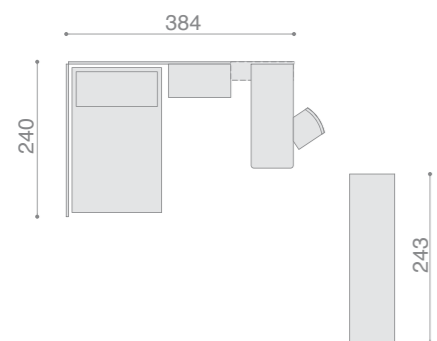





Armadio ante scorrevoli **Puzzle**; letto **Cocoon** con interno testiera rivestito in tessuto; libreria ponte con scrittoio su gambe **Diapason**. Finiture: melaminico Bianco; laccato Verde Acido e Canapa; inserto anta Puzzle laccato Verde Bosco.

Puzzle wardrobe with sliding doors; **Cocoon** bed with padded headboard inside; overhead bookcase with desk with **Diapason** legs. Finishes: White melamine; Acid Green and Hemp lacquered; lacquered inserts on **Puzzle** wardrobe doors: Wood green.

Armoire portes coulissantes **Puzzle**; lit **Cocoon** avec intérieur tête revêtu; bibliothèque pont avec bureau sur pieds **Diapason**. Finitions: Blanc mélaminé, Laqué Vert Acide et Chanvre; empiècement porte **Puzzle** laqué Vert bois.

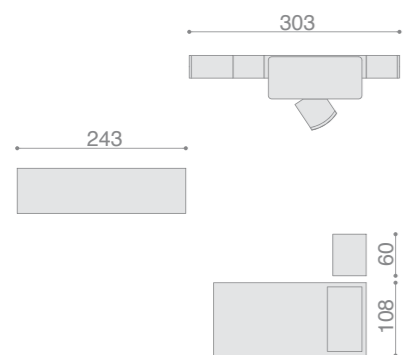



01 STARTLETTI



LETTO / BED **COCOON**



LETTO / BED **ROMANTIC**



LETTO / BED **LULLY**

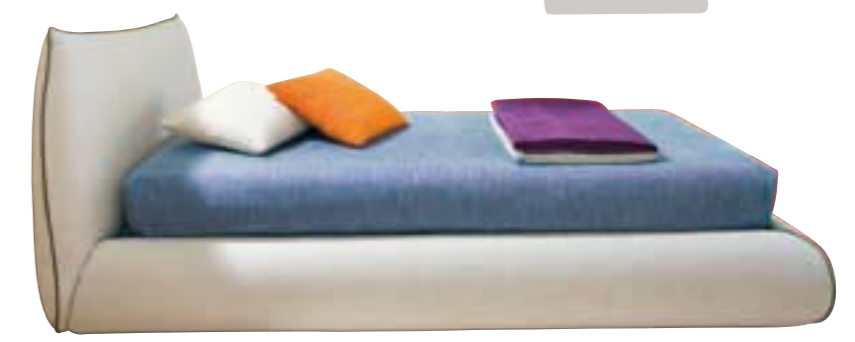

LETTO / BED **DOLL**







Armadio ante scorrevoli **Duo** vetro laccato; letto **Cocoon**; boiserie verticale con mensole; scrittoio sp. 50 in appoggio; contenitori con cassetti su panca sp. 50.
 Finiture: melaminico Bianco, Panca sp. 50 melaminico Frassino; laccato Ocre e Bianco Giglio.

Duo wardrobe with lacquered glass sliding doors; **Cocoon** bed; vertical boiserie with shelves; 50 mm thick raised desk; cabinets with drawers mounted on a 50 mm thick low shelf.
 Finishes: melamine White, 50 mm thick low shelf in ashwood melamine; lacquers Ochre and Lily White.

Armoire portes coulissantes **Duo** verre laqué; lit **Cocoon**; boiserie verticale avec étagères; bureau ép. 50 en appui; meubles de rangement avec tiroirs sur banc ép. 50.
 Finitions: mélaminé Blanc, Banc ép. 50 mélaminé Frêne; laqués Ocre et Blanc Lys.

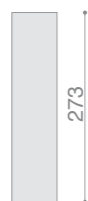
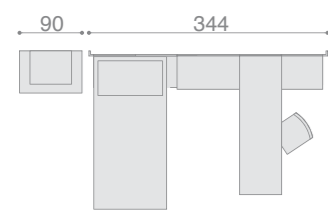





Armadio ante scorrevoli **Puzzle**;
 letto **Romantic** con pannello retro-
 letto; Libreria con ante sagomate e
 scrittoio **Romantic** integrato; sedia
 trasparente **Gliss**.
 Finiture: melaminico Bianco; lac-
 cato Mango; ante Puzzle laccato
 Bianco Giglio con inserto Canapa
 pannello retroletto Moka.

Puzzle wardrobe with sliding do-
 ors; **Romantic** bed with rear pa-
 nel; Bookcase with shaped doors
 and built-in **Romantic** desk; **Gliss**
 transparent chair.
 Finishes: White melamine; Mango
 lacquered; Lily White lacquered
 Puzzle doors with Hemp insert.
 Moka wall panel behind bed.

Armoire portes coulissantes **Puzzle**;
 lit **Romantic** avec panneau arrière-
 lit; Bibliothèque avec portes façon-
 nées et bureau **Romantic** intégré;
 chaise transparente **Gliss**.
 Finitions: Mélangé Blanc; laqués
 Mangue; portes Puzzle laqué
 Blanc lys avec empiècement Chan-
 vre panneau arrière-lit Moka.

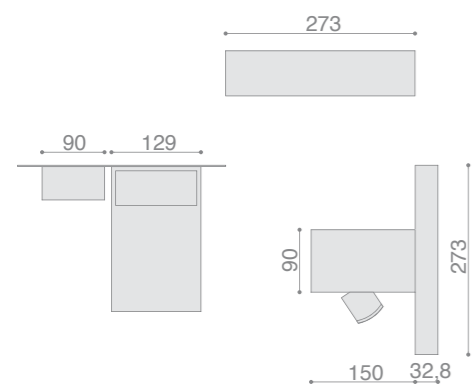

START LIBRERIE IN MOVIMENTO

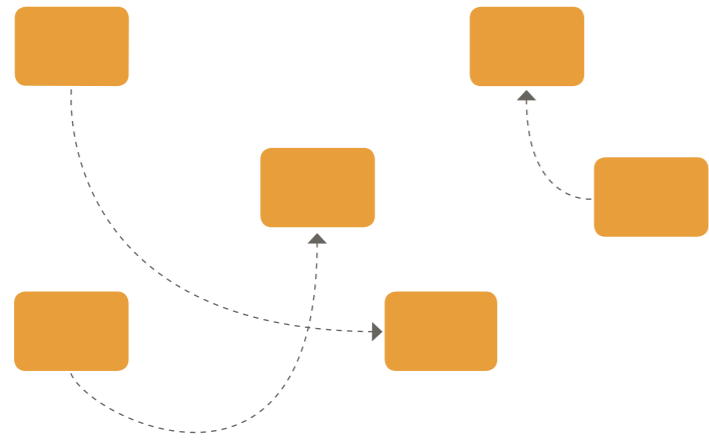

Le ante sagomate possono essere collocate a piacimento sui vani della libreria.

The shaped doors can also be used to close the bookcase compartments.

Les portes façonnées peuvent être placées au choix sur les compartiments de la bibliothèque.





In questa libreria le ante sono circolari e a destra si nota il particolare dell'apertura senza maniglia.

This bookcase is finished with circular doors. The picture to the right shows how the circular doors are opened without the use of handles.

Dans cette bibliothèque, les portes sont circulaires et à droite on remarque le détail de l'ouverture sans poignée.

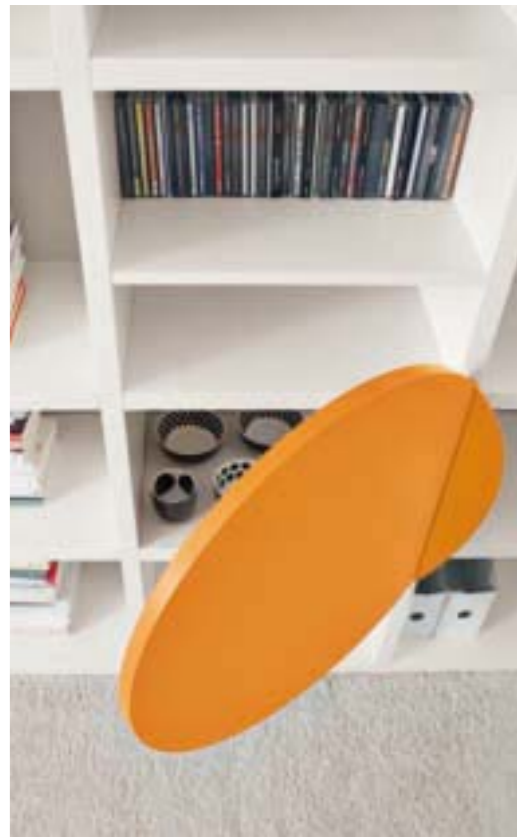





Armadio ante scorrevoli **Duo** vetro laccato; letto pianale **Karta** e testiera imbottita; boiserie orizzontale con scrittoio scorrevole su gamba **Diapason**; libreria con ante battenti e a ribalta in vetro laccato, a terra ed in appoggio su basi con cassetti. Casellario orizzontale **Multiplo**; sedia **Harmony**.
 Finiture: melaminico Bianco e Rovere Moro; laccato Bianco Giglio, Canapa e Fucsia.

Duo wardrobe with lacquered glass sliding doors; **Karta** platform bed with upholstered headboard; horizontal boiserie with sliding desk with **Diapason** leg; bookcase - free-standing and mounted on base units with drawers - with hinged and flap doors in lacquered glass. **Multiplo** horizontal shelving unit; **Harmony** chair.
 Finishes: White, Dark Oak; lacquers Lily, Hemp, Fuchsia.

Armoire portes coulissantes **Duo** verre laqué; lit plateforme **Karta** et tête rembourée; boiserie horizontale avec bureau coulissant sur pied **Diapason**; bibliothèque avec portes battantes et relevables en verre laqué, Au sol et en appui sur les éléments bas avec tiroirs. casier horizontal **Multiplo**; chaise **Harmony**.
 Finitions: Blanc, Chêne Rouvre foncé; laqués lys, Chanvre, Fuchsia.

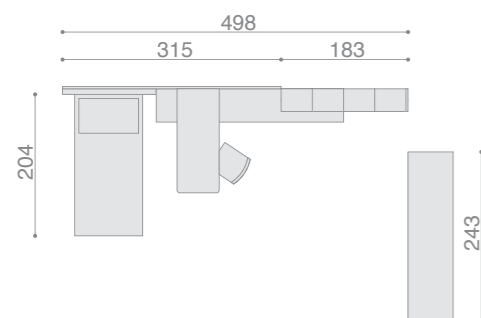





Armadio con ante scorrevoli **Puzzle**, Boiserie **Virtual** con piano lavoro, sedia **Harmony**, letto **Romantic** con gambe **Slim**.
 Finiture: melaminico Bianco; Flowers Orchidea e Mimosa.

Puzzle wardrobe with sliding doors, **Virtual** boiserie with desk, **Harmony** chair, **Romantic** bed with **Slim** legs.
 Finitures: White melamine; Flowers Orchid and Mimosa.

Armoire avec portes coulissantes **Puzzle**, Boiserie **Virtual** avec plan de travail, chaise **Harmony**, lit **Romantic** avec pieds **Slim**.
 Finitions: mélaminé Blanc; Flowers Orchidée et Mimosa.

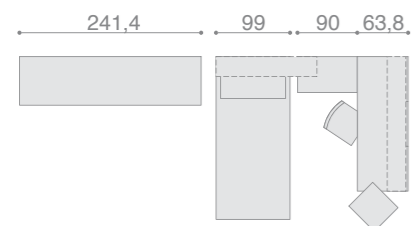







Cabina armadio; letto alla turca su ruote e libreria retroletto; contenitori pensili con anta ribalta; scrittoio con gambe **Slim** e casellario **Cross**, contenitore su ruote **Round**; sedia **Harmony**.
 Finiture: cabina Flowers Orchidea con interno Bianco; laccato Lilla e Ambra.

Walk-in wardrobe; divan bed on wheels; bookcase behind bed; suspended cabinets with flap doors; desk with **Slim** legs and **Cross** shelving unit, **Round** cabinet on wheels; **Harmony** chair.
 Finishes: walk-in wardrobe Flowers Orchid with White interior; lacquers Lilac, Amber.

Cabine armoire; lit à la turque sur roues et bibliothèque arrière-lit; éléments hauts de rangement avec porte relevable; bureau avec pieds **Slim** et casier **Cross** élément de rangement sur roues **Round**; chaise **Harmony**.
 Finitions: Cabine Flowers Orchidée avec intérieur Blanc; laqués Mauve, Ambre.

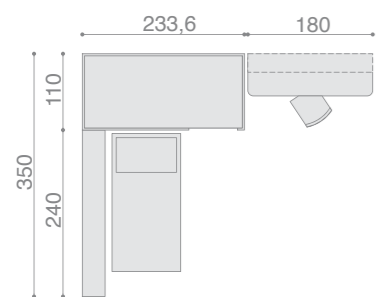





Armadiatura pensile con Letto apribile **Wagon**; letto **Casper**; Libreria box con piano lavoro ribaltabile; sedia **Harmony**; casellari **Cross**; contenitore su ruote **Round**.
Finiture: melaminico Bianco; laccato Mango e Miami.

Suspended wardrobe with **Wagon** fold-away bed; **Casper** bed; box bookcase with flap desk; **Harmony** chair; **Cross** wall panels; **Round** cabinet on wheels.
Finishes: White melamine; lacquers Mango and Miami.

Système d'armoire haute avec lit ouvrant **Wagon**; lit **Casper**; Bibliothèque box avec plan travail rabattable; chaise **Harmony**; panneaux muraux **Cross**; meuble de rangement sur roues **Round**.
Finitions: mélaminé Blanc; laqués Mangué et Miami.

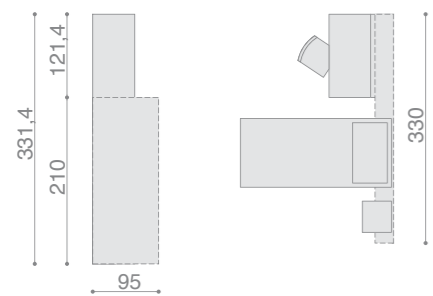







Armadiatura pensile; scrittoio girevole, su contenitori, con gamba **Diapson**; letto tessile **Doll** rifinito con cordonatura con pannello retro letto sagomato; comodino due cassetti, libreria in appoggio su contenitori; sedia **Harmony**.
 Finiture: melaminico Bianco e Frasinio; laccato Tramonto.

Suspended wardrobe; swivel desk with **Diapson** leg mounted on cabinets; **Doll** bed with fabric cover with trim detail and shaped rear panel; bedside table with two drawers, bookcase mounted on cabinets; **Harmony** chair.
 Finishes: White melamine and Ashwood; lacquers Sunset.

Système d'armoire haute: bureau tournant, sur éléments de rangement avec pied **Diapson**; lit textile **Doll** fini avec cordons avec panneau arrière lit façonné; table de nuit deux tiroirs, bibliothèque en appui sur éléments de rangement; chaise **Harmony**.
 Finitions: melaminé Blanc, Frêne; laqués Coucher de soleil.









Letti **Tex** con cuscino rivestito; casellario orizzontale **Multiplo** e mensole sp. 50; scrittoi sp. 50 con gambe **Diapason** in appoggio su contenitori; casellari **Cross**, sedie **Coral**.

Finiture: melaminico Frassino; laccato Ambra e Tramonto.

Tex beds with cushion; **Multiplo** horizontal shelving unit and 50 mm thick shelves; 50 mm thick desks with **Diapason** legs mounted on cabinets; **Cross** shelving units, **Coral** chair.

Finishes: Ashwood melamine, lacquers Amber and Sunset.

Lits **Tex** avec coussin revêtu; casier horizontal **Multiplo** et étagères ép. 50 avec pieds **Diapason** en appui sur éléments de rangement; casier **Cross**, chaises **Coral**.

Finitions: mélaminé Frêne; laqués Ambre et Coucher de soleil.

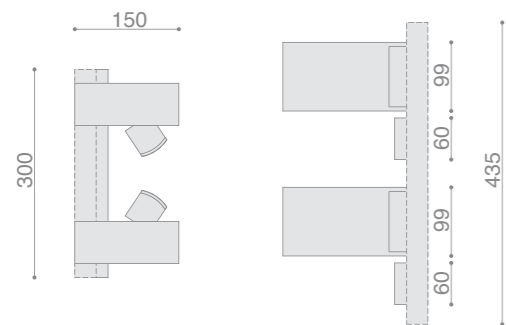









Armadiatura pensile; libreria box con piano lavoro ribaltabile; contenitore base con cassetti; letto/divano polifunzionale **Lobby Pair** con movimento orizzontale; contenitori a parete **Round**; sedie **Gliss**.

Finiture: melaminico Bianco; laccato Antracite e Verde Acido.

Suspended wardrobe; box bookcase with flap desk; base cabinet with drawers; **Lobby Pair** multi-function bed/sofa with horizontal movement; **Round** wall cabinets; **Gliss** chair.

Finishes: White melamine; lacquers Anthracite and Acid Green.

Système d'armoires suspendues; bibliothèque box avec plan de travail rabattable; conteneur base avec tiroirs; lit /divan multifonction **Lobby Pair** avec mouvement horizontal; conteneur muraux **Round**; chaises **Gliss**.

Finitions : mélaminé Blanc; laqués Anthracite et Vert Acide.

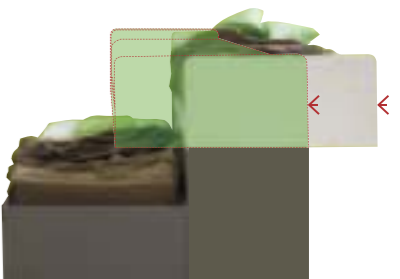



Il letto polifunzionale **Lobby Pair** di giorno è un comodo divano mentre la sera facendo scorrere il letto superiore si trasforma in due comodi posti letto, il letto inferiore è dotato di cassetti e capienti cassettoni.

The **Lobby Pair** multi-function bed is a comfortable sofa during the day and is easily transformed into two practical beds. The lower bed is fitted with spacious drawers and deep drawers.

Le lit polyfonctionnel **Lobby Pair** de jour est un canapé confortable alors que le soir, en faisant coulisser le lit supérieur, il se transforme en deux places de lits confortables, le lit inférieur est doté de tiroirs et de grands tiroirs spacieux.

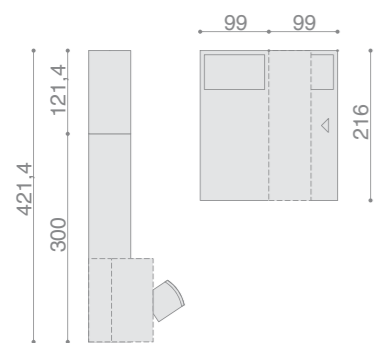





Armadiatura pensile con libreria box; letto a soppalco **Lobby Slide** con movimento orizzontale; letto **Romantic** su ruote.
 Finiture: melaminico Ciliegio; armadi pensili Flowers Aloe; laccato Verde Bosco.

Suspended wardrobe with box bookcase; **Lobby Slide** loft bed with horizontal movement; **Romantic** bed on wheels.
 Finishes: Cherrywood melamine; suspended wardrobes Flowers Aloe; lacquers Wood Green.

Système d'armoire haute avec bibliothèque box; lit à mezzanine **Lobby Slide** avec mouvement horizontal; lit **Romantic** sur roues.
 Finishes: mélaminé Cerisier; armoires hautes Flowers Aloe; laqués Vert Bois.

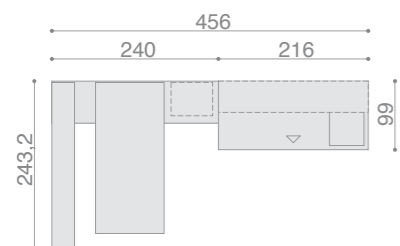







Cabina armadio; letti polifunzionale con cassettoni e cassetti; letto **Lobby 3** con terzo letto estraibile; casellari a parete **Add e Round**; contenitore su ruote **Round**.
 Finiture: melaminico Bianco; laccato Ambra e Melanzana.

Walk-in wardrobe; multi-function beds with deep drawers and drawers; **Lobby 3** bed with slide-out bed; **Add and Round** wall shelving units; **Round** cabinet on wheels.

Finishes: White melamine; lacquers Amber and Aubergine.

Cabine armoire; lits polyfonctionnels avec grands tiroirs et tiroirs; lit **Lobby 3** avec troisième lit extractible; casiers muraux **Add et Round**; élément de rangement sur roues **Round**.

Finitions: mélaminé Blanc; laqués Ambre et Aubergine.

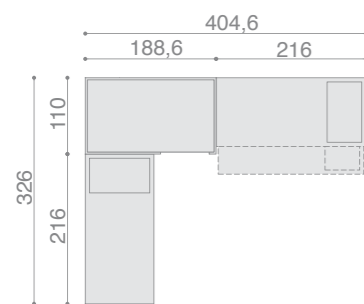





Armadiatura pensile con ante **Oblò**; librerie box; letto scorrevole; letto tessile **Less**; scrittoio con schienale imbottito uso testiera per letto **Less**; casellari a parete **Home**, sedia trasparente **Gliss**; contenitore **Round** su ruote.
 Finiture: melaminico Bianco laccato Canapa e Tramonto.

Suspended wardrobe with **Oblò** doors; box bookcases; sliding bed; **Less** bed with fabric cover; desk with padded back that becomes a headboard for the **Less** bed; **Home** wall shelving units, **Gliss** transparent chair; **Round** cabinet on wheels.
 Finishes: White melamine; lacquers Hemp and Sunset.

Système d'armoire haute avec portes **Oblò**; bibliothèques box; lit coulissant; lit textile **Less**; bureau avec dos rembourré utilisation tête pour lit **Less**; Casiers muraux **Home**, chaise transparente **Gliss**; élément de rangement **Round** sur roues.
 Finitions: Mélangé Blanc; laqués Chanvre, Coucher de soleil.

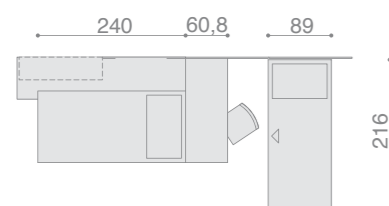







Armadiatura pensile; libreria con scrittoio **Romantic**; letto a castello **Dual** con protezione ribaltabile e scala a gradini con pedana; letto tessile **Less**; contenitore **Round** su ruote; sedia trasparente **Gliss**.
 Finiture: melaminico Bianco e Frassino; laccato Lilla.

Suspended wardrobe; bookcase with **Romantic** desk; **Dual** loft bed with hinged guard rail and steps with platform; **Less** bed with fabric cover; **Round** cabinet on wheels; **Gliss** transparent chair.
 Finishes: White and Ashwood melamine; lacquers Lilac.

Système d'armoire haute; bibliothèque avec bureau **Romantic**; lit superposé **Dual** avec protection relevable et échelle à marches avec estrade; lit textile **Less**; élément de rangement **Round** sur roues; chaise transparente **Gliss**.
 Finitions: mélaminé Frêne et Blanc; laqués Mauve.

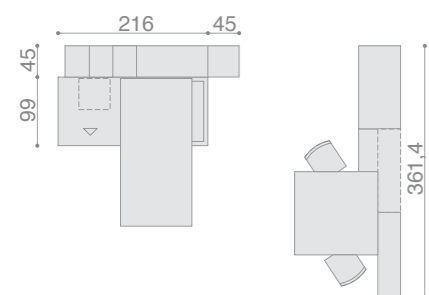



1.
YOUTH
(UNBROKEN)



Amadio ante scorrevoli **Puzzle**; letto castello **Chance** con scrittoio e secondo letto a scomparsa totale; scala con pedana; boiserie verticale "Virtual".
 Finiture: melaminico Frassino; Flowers Aloe e Flowers Orchidea; laccato Lilla.

Puzzle wardrobe with sliding doors; **Chance** loft bed with desk and hide-away low bed; steps with platform; vertical boiserie "Virtual".

Finishes: Ashwood melamine; Flowers Aloe and Flowers Orchid; lacquers Lilac.

Armoire portes coulissantes **Puzzle**; lit superposé **Chance** avec bureau et deuxième lit complètement escamotable; échelle avec estrade; boiserie verticale "Virtual".
 Finitions: mélaminé Frêne, Flowers Aloe, Flowers Orchidée; laqués Mauve.

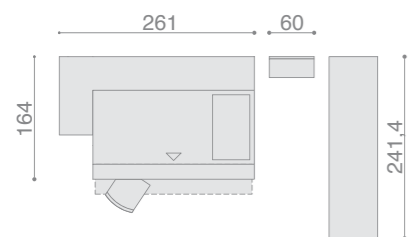

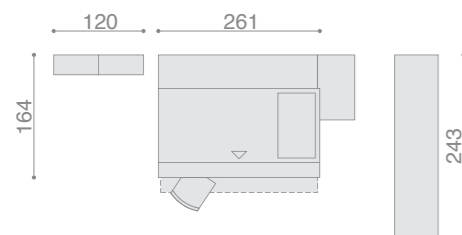

Armadio Start con ante **Stripes**; letto castello **Chance** con scrittoio, secondo letto a scomparsa totale e protezione ribaltabile con cuffia; casellari a parete **Cross**, sedia **Harmony**.
 Finiture: melaminico Bianco e Frasinio; Flowers Ortensia; laccato Tramonto.

Start wardrobe with **Stripes** doors; **Chance** loft bed with desk, hide-away low bed and hinged guard rail with cover; **Cross** wall shelving units, **Harmony** chair.
 Finishes: Ashwood and White melamine; Flowers Hydrangea; lacquers Sunset.

Armoire Start avec portes **Stripes**; lit superposé **Chance** avec bureau, deuxième lit complètement escamotable et protection relevable avec revêtement; casiers muraux **Cross**, chaise **Harmony**.
 Finitions: mélaminé Blanc et Frêne; Flowers Hortensia; laqués Couché de soleil.





Armadiatura pensile; letto polifunzionale con cassettoni; scrittoio con cassetiera; casellari Cross; pouf.

Suspended wardrobe; multi-function bed with deep drawers; desk with drawer cabinet; Cross shelving units; pouf.

Systeme d'armoire haute; lit polyfonctionnel avec grands tiroirs; bureau avec tiroirs; casiers Cross; pouf.

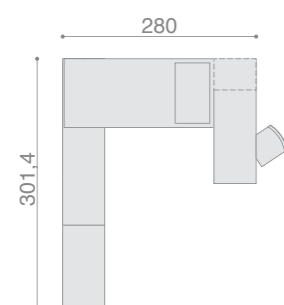





Armadiatura a ponte con cabina angolare; letto **Romantic**; comodino con cassetti; libreria con ante a ribalta e scrittoio **Romantic**; casellario orizzontale **Multiplo**; pouf.
 Finiture: melaminico Bianco e Frasinio; laccato Lilla.

Overhead wardrobe system with corner walk-in wardrobe; **Romantic** bed; bedside table with drawers; **Romantic** bookcase with flap doors and desk; **Multiplo** horizontal shelving unit; pouf.
 Finishes: Ashwood and White melamine; lacquers Lilac.

Système d'armoire haute à pont avec cabine d'angle; lit **Romantic**; table de nuit avec tiroirs; bibliothèque avec portes relevables et bureau **Romantic**; casier horizontal **Multiplo**; pouf.
 Finitions: mélaminé Blanc et Frêne; laqué Mauve.

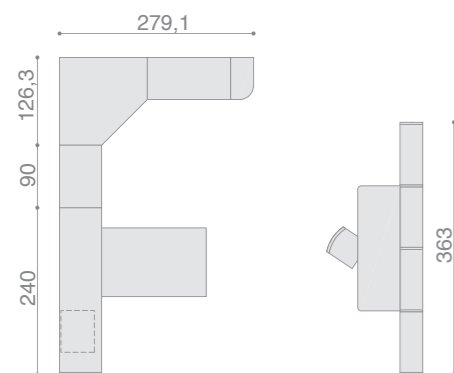









Armadiatura a ponte; letto Lobby 1 soluzione con tre letti ad estrazione; box libreria con piani lavoro ribaltabili; pouf.
 Finiture: melaminico Bianco; laccato Mango, Verde Bosco e Verde Acido.

Overhead wardrobe system; Lobby 1 bed solution with three slide-out beds; box bookcase with tilting tops; pouf.
 Finishes: White melamine; lacquers Mango, Wood Green and Acid Green.

Cabine armoire; lits polyfonctionnels avec grands tiroirs et tiroirs; lit Lobby 1 avec troisième lit extractible; bibliothèques box avec plan de travail rabattable; pouf.
 Finitions: mélaminé Blanc; laqués Mangué, Vert Bois et Vert Acide.

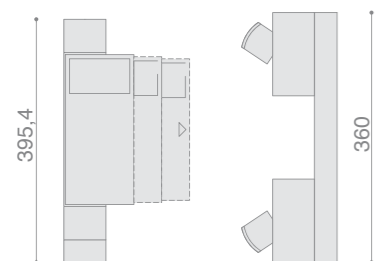





Armadiatura a ponte con scrittoio integrato e Ponte con fianco metallo; letti tessili **Less** e cubotto di separazione uso testata, contenitori **Round**, pouf.
 Finiture: melaminico Bianco; laccato Mango e Fucsia.

Overhead wardrobe system with built-in desk and overhead wardrobe with metal side; **Less** beds with fabric cover separated by a cube-shaped headboard, **Round** cabinets, pouf.

Finishes: White melamine; lacquers Mango et Fuchsia.

Système d'armoire à pont avec bureau intégré et Pont avec côté métal; lits textiles **Less** et petit cube de séparation utilisation tête, éléments de rangement **Round**, pouf.
 Finitions: mélaminé Blanc; laquers Manguet Fuchsia.

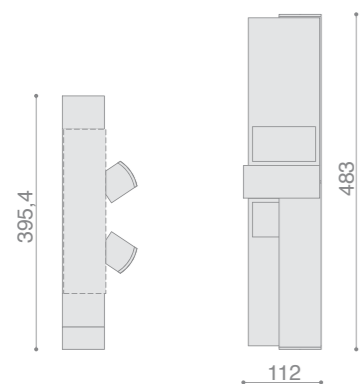







Armadiatura a ponte con ante **Stripes**; letto **Lobby 3**; boiserie orizzontali con casellari **Multiplo**, contenitori base con cassetti e scrittoio scorrevole su gambe **Diapason**; sedia **Coral** con seduta imbottita. Finiture: melaminico Bianco; laccato Bianco Giglio, Ocra e Antracite.

Overhead wardrobe system with **Stripes** doors; **Lobby 3** bed; horizontal boiserie with **Multiplo** shelving units, base cabinets with drawers and sliding desk with **Diapason** legs; **Coral** chairs with padded seat. Finishes: White melamine; lacquers Lily White, Ochre and Anthracite.

Système d'armoire à pont avec portes **Stripes**; lit **Lobby 3**; boiserie horizontales avec casiers **Multiplo**, éléments bas de rangement avec tiroirs et bureau coulissant sur pieds **Diapason**; chaise **Coral** avec siège rembourré. Finitions: mélaminé Blanc; laqués Blanc Lys, Ochre et Anthracite.

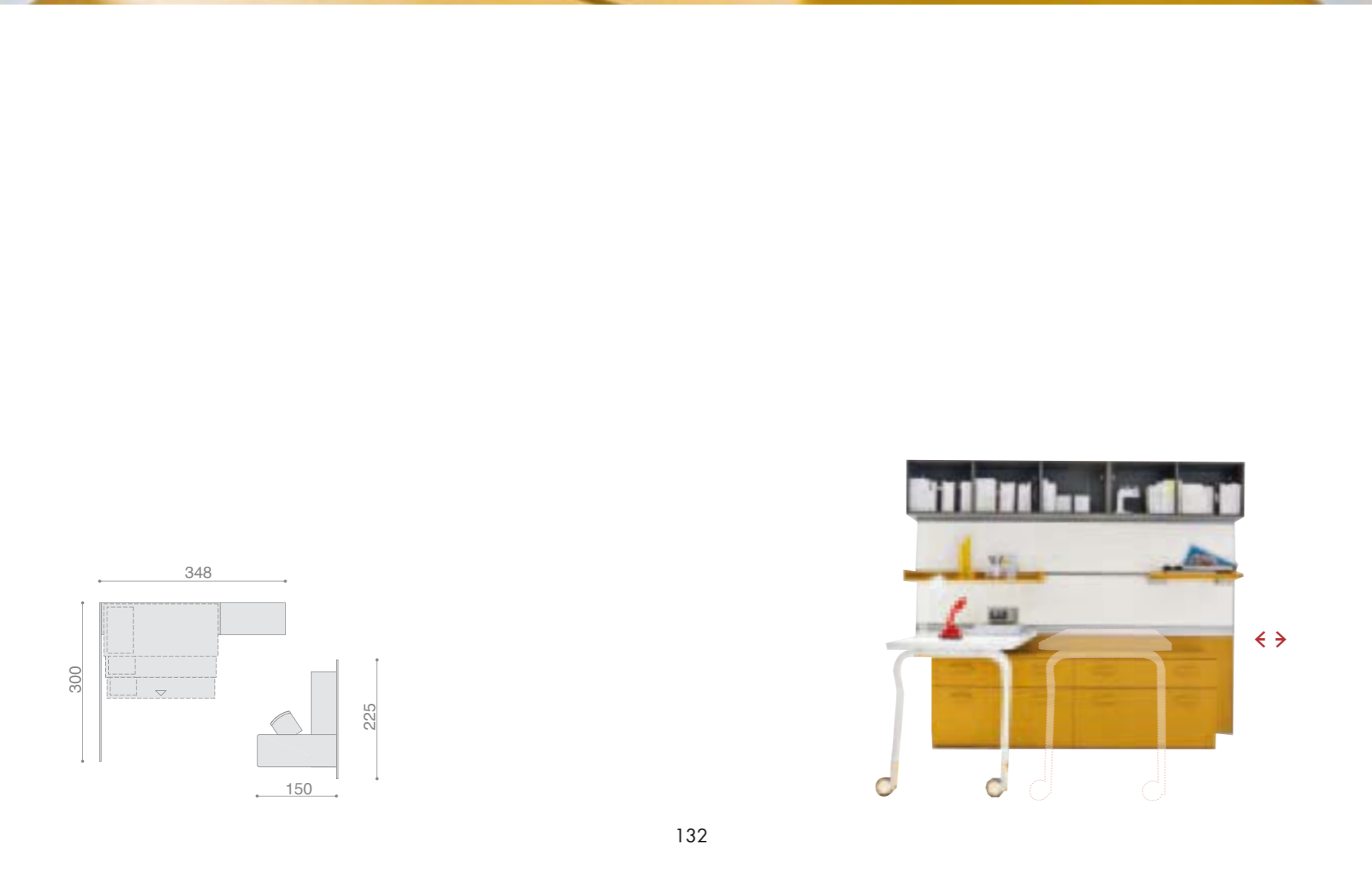

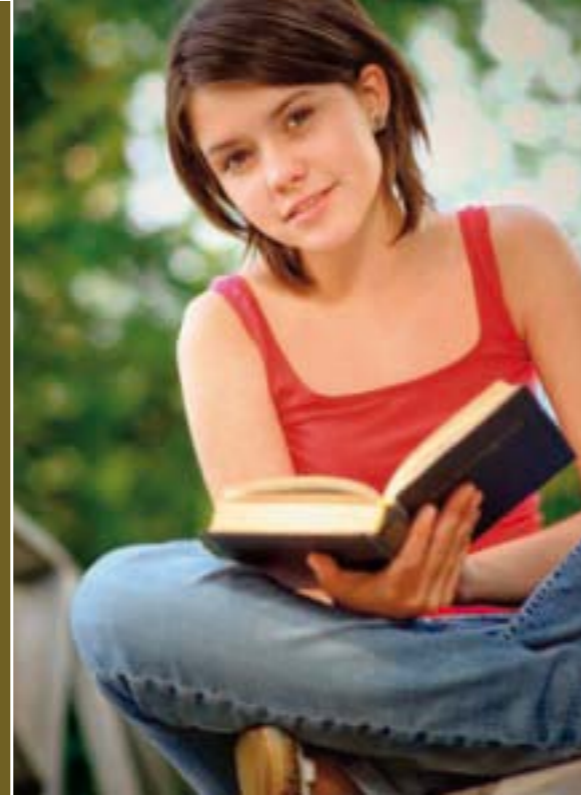





Armadiatura a ponte; letto a sopralco con scaletta e protezione; letto tessile **Less**; box libreria con piano estraibile; contenitori **Round** a parete; sedia trasparente **Gliss**.
 Finiture: melaminico Bianco e Ciliegio; laccato Verde Acido.

Overhead wardrobe system; loft bed with ladder and guard rail; **Less** bed with fabric cover; box bookcase with slide-out desk; **Round** wall cabinets; **Gliss** transparent chair.
 Finishes: Cherrywood and White melamine; lacquers Acid Green.

Système d'armoire à pont; lit à mezzanine avec petite échelle et protection lit textile **Less**; box bibliothèque avec plan extractible; éléments éléments de rangement **Round** muraux; chaise transparente **Gliss**.
 Finitions: mélaminé Blanc et Cerisier; laqués Vert Acide.

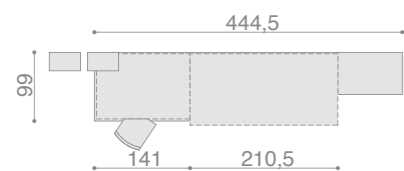





Cabina armadio angolare con terminale libreria; armadio pensile con librerie; letto castello scorrevole **Dual** a coprire la scala con protezioni; letto tessile **Less**; contenitori a parete **Round**.
 Finiture: melaminico Bianco; laccato Verde Acido e Melanzana.

Corner walk-in wardrobe with side-end bookcase; suspended wardrobe with bookcases; **Dual** sliding bunk bed (the top bed slides over the steps and guard rail); **Less** bed with fabric cover; **Round** wall cabinets.
 Finishes: White melamine; lacquers Acid Green and Aubergine.

Cabine armoire d'angle avec terminaison bibliothèque, armoire haute avec bibliothèques, lit superposé coulissant. **Dual** pour couvrir l'échelle avec protections, lit textile **Less** éléments muraux de rangement **Round**.
 Finitions: mélaminé Blanc; laqués Vert Acide et Aubergine.

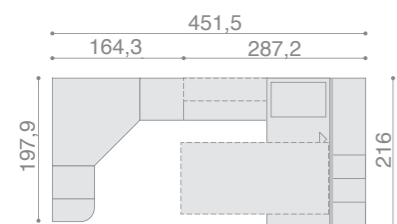







Armadiatura pensile; box libreria con piano lavoro ribaltabile; letto a soppalco **Lobby Slide** con movimento orizzontale su armadio con ante scorrevoli; letto **Nadir** con cuffia **Romantic**.
 Finiture: Armadi pensili Flowers Ortensia, ante scorrevoli Flowers Aloe; laccato Miami e Moka.

Suspended wardrobe; box bookcase with flap desk; **Lobby Slide** loft bed with horizontal movement; wardrobe with sliding doors; **Nadir** bed with **Romantic** cover.
 Finishes: suspended wardrobes: Flowers Hydrangea, sliding doors: Flowers Aloe; lacquers Miami and Moka.

Système d'armoire haute box bibliothèque avec plan de travail rabattable; lit en mezzanine **Lobby Slide** avec mouvement horizontal sur armoire avec portes coulissantes lit **Nadir** avec revêtement **Romantic**.
 Finitions: Armoires hautes Flowers Hortensia, portes coulissantes Flowers Aloe; laqués Miami, Moka.

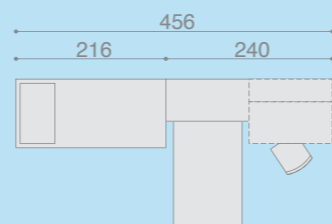
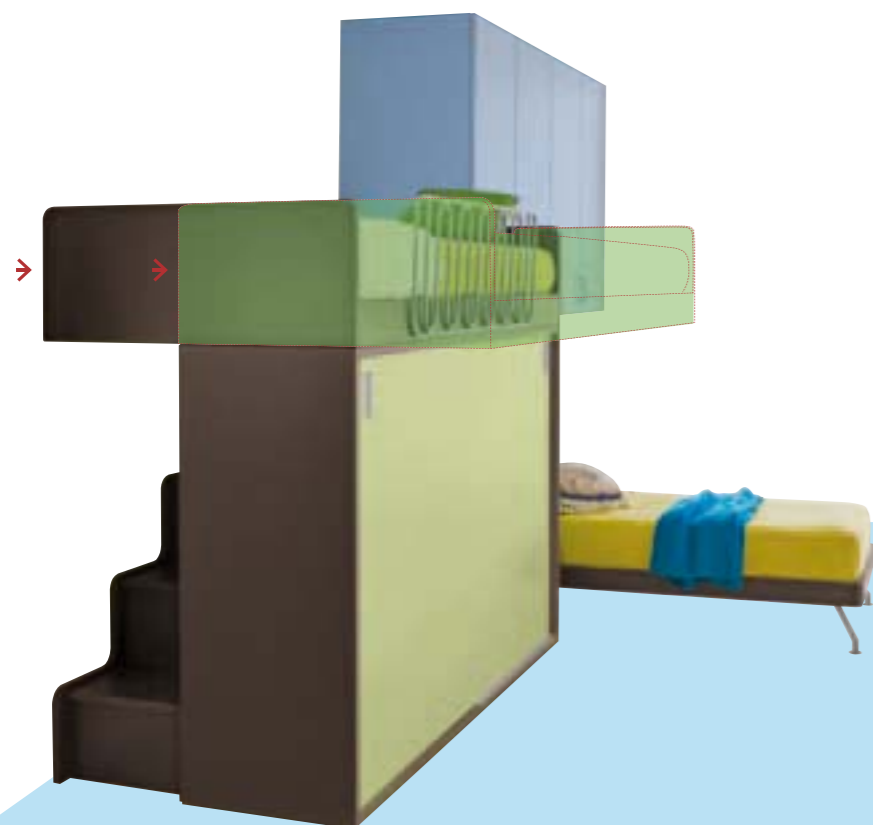





Armadiatura pensile; letto **Lobby Box** con 2 cassettoni; box retro letto con vano estraibile; scrittoio sagomato; contenitori **Round** su ruote; sedia trasparente **Gliss**.
 Finiture: melaminico Bianco; ante Flowers Ortensia; laccato Blu Iris e Celeste.

Suspended wardrobe; **Lobby Box** bed with 2 deep drawers; box behind bed with slide-out compartment; shaped desk; **Round** cabinets on wheels; **Gliss** transparent chair.
 Finishes: White melamine; doors: Flowers Hydrangea; lacquers Iris Blue, Light Blue.

Système d'armoire haute lit **Lobby Box** avec 2 grands tiroirs; box arrière-lit avec compartiment extractible; bureau façonné, éléments de rangement **Round** sur roues; chaise transparente **Gliss**.
 Finitions: mélaminé Blanc, portes Flowers Hortensia; laqués Bleu Iris, Céleste.

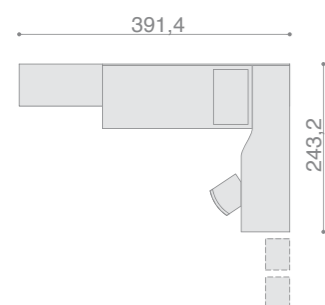







Armadiatura pensile; boiserie con letti e scrittoio scorrevoli; basi a terra con cassetti; casellario orizzontale **Multiplo**.
 Finiture: melaminico Bianco e Frassino; laccato Blu Iris e Celeste.

Suspended wardrobe; boiserie with beds and sliding desk; floor-standing base cabinets with drawers; **Multiplo** horizontal shelving unit.
 Finishes: melamine White, Ashwood; Lacquers Iris Blue, Light Blue.

Système d'armoire haute; boiserie avec lits et bureau coulissants; éléments bas au sol avec tiroirs, casier horizontal **Multiplo**.
 Finitions: mélaminé Blanc, Frêne laqués/ Bleu, Iris, Céleste.

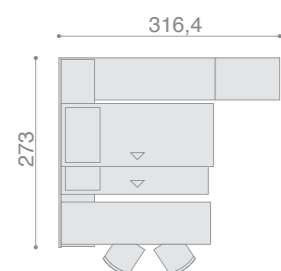



Armadio ad ante con maniglia **Tower**; letto castello **Dual** con piano scrittoio estraibile e scala posteriore, casellario **Wings**, sedia **Riviera**.

Finiture: Flowers Calla e Orchidea; laccato Lilla.

Wardrobe doors with **Tower** handles; **Dual** loft bed with with slide-out desk and rear ladder, **Wings** shelving unit, **Riviera** chair. Finishes: Flowers Calla and Orchid; lacquers Lilac.

Armoire portes avec poignées **Tower**; lit superposé **Dual** avec plan bureau extractible et échelle postérieure, casier **Wings**, chaise **Riviera**.

Finitions: Flowers Calla et Orchidée; laqués Mauve.

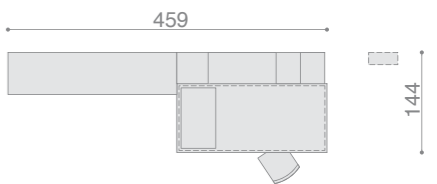







Armadiatura a ponte con ante battenti e ante scorrevoli **Puzzle**; boiserie orizzontale con letti scorrevoli; scrittoio sagomato con gambe **Slim** in appoggio su contenitore; casellario **Wings**; sedia **Coral** con seduta imbottita.
Finiture: melaminico Bianco; laccato Lilla e Melanzana.

Puzzle overhead wardrobe system with hinged and sliding doors; horizontal boiserie with sliding beds; Shaped desk with **Slim** legs, mounted on a cabinet; **Wings** shelving unit; **Coral** chair with padded seat.
Finishes: melamine White; lacquers Lilac, Aubergine.

Système d'armoire à pont avec portes battantes et portes coulissantes **Puzzle**; boiserie horizontale avec lits coulissants; bureau façonné avec pieds **Slim** en appui sur élément de rangement; casier **Wings**; chaise **Coral** avec siège rembourré.
Finitions: mélaminé Blanc; laqués Mauve, Aubergine.

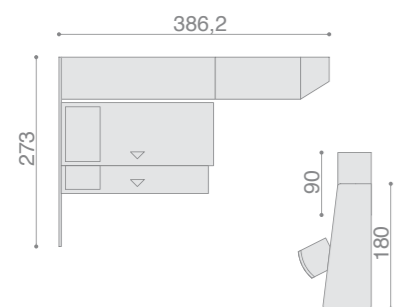





Armadiatura a ponte, letto **Lobby 3** più secondo letto polifunzionale con cassettoni; casellario **Add**; cassetiera su ruote; boiserie verticale **Virtual** con scrittoio su gambe **Toy** e sedia **Coral**.
Finiture: melaminico Bianco; laccato Verde acido e Lilla.

Overhead wardrobe system, **Lobby 3** bed with multi-function low bed with deep drawers; **Add** shelving unit; drawer cabinet on wheels; vertical boiserie **Virtual** with desk on **Toy** legs and **Coral** chair.
Finishes: melamine White; lacquers Acid Green, Lilac.

Système d'armoire à pont, Lit **Lobby 3** plus deuxième lit polyfonctionnel avec grands tiroirs, casier **Add**; meuble à tiroirs sur roues; Boiserie verticale **Virtual** avec bureau sur pieds **Toy** et chaise **Coral**.
Finitions: mélaminé Blanc; laqués vert acide, Mauve.

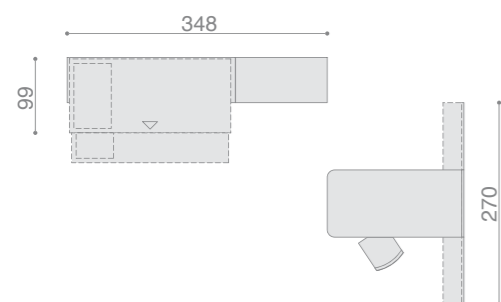



Boiserie verticale **Virtual** con due piani lavoro e piano porta stampante.

Vertical boiserie **Virtual** with two desks and printer shelf.

Boiserie verticale **Virtual** avec deux plans de travail et plan porte-imprimante.







Lettoino **Castle** con tendine e scaletta; letto scorrevole **Karta** con cuffia ricamata; basi a terra con cassetti; scrittoio con sedia **Harmony** e mensole **L**.
 Finiture: melaminico Frassino; laccato Verde Acido.

Castle loft bed with curtains and steps; **Karta** sliding bed with embroidered headboard cover; floor-standing cabinets with drawers; desk with **Harmony** chair and L-shaped shelves.
 Finishes: Ashwood melamine; lacquer Acid Green.

Lit d'enfant **Castle** avec petits rideaux et échelle. Lit coulissant **Karta** avec cuffie brodée; éléments bas au sol avec tiroirs; bureau avec chaise **Harmony** et étagères à L.
 Finitions: mélaminé Frêne; laqués Vert Acid.

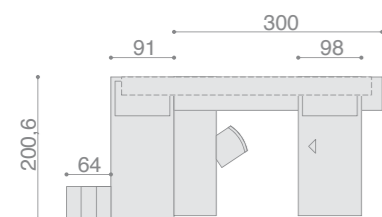

02 NIGHT&MORE

UNO SPAZIO POLIFUNZIONALE | A MULTI-FUNCTION SPACE | UN ESPACE POLYFONCTIONNEL







Armadio ante scorrevoli **Duo**; letto scorrevole su panca a terra **Karta** con testiera imbottita; piano di lavoro in appoggio su cassetiera con alloggiamento testiera; contenitori pensili; mensole sp. 50. Finiture: melaminico Frassino; laccato Bianco Giglio e Fucsia.

Duo Wardrobe with sliding doors; **Karta** sliding bed with padded headboard, mounted on a low shelf; desk mounted on a drawer cabinet, complete with head-board compartment; suspended cabinets; 50 mm thick shelves. Finishes: Ashwood melamine; lacquers Lily White and Fuchsia.

Armoire portes coulissantes **Duo**; lit coulissant sur banc au sol **Karta** avec tête rembourrée, plan de travail en appui sur meuble à tiroirs avec logement tête; éléments hauts de rangement; étagères ép. 50. Finitions: mélaminé Frêne; laqués Blanc Lys et Fuchsia.

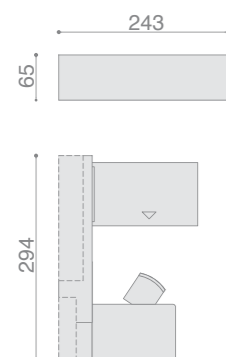



Letto **Karta**; piano di lavoro sp. 50; cassetiera su ruote, poltroncina imbottita casellario orizzontale **Multiplo**; contenitori pensili con apertura a push.

Finiture: melaminico Rovere Moro; laccato Bianco Giglio e Fucsia.

Karta bed; 50 mm thick desk; drawer cabinet on wheels, padded chair; **Multiplo** horizontal shelving unit; suspended cabinets with push opening.

Finishes: Dark Oak melamine; lacquers Lily White and Fuchsia.

Lit **Karta**; plan de travail ép. 50; meuble à tiroirs sur roues, fauteuil rembourré casier horizontal **Multiplo**; éléments hauts de rangement avec ouverture push.

Finitions: Chêne Rouvre foncé; laqués Blanc Lys et Fuchsia.

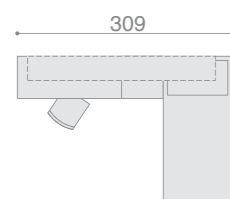





Armadio battente con fianco laterale sp. 50; boiserie verticale ad angolo con pannelli e specchi attrezzata con ripiani, contenitori pensili e appendiabiti; base con cassetti in appoggio su panca sp. 50; Letto tessile **Less**.
 Finiture: melaminico Rovere Moro; laccato Canapa e Fucsia.

Wardrobe with hinged doors with 50 mm thick side; vertical corner boiserie with panels and mirrors, complete with shelves, suspended cabinets and clothes hanging rails; base unit with drawers mounted on a 50 mm thick low shelf; **Less** bed with a fabric cover.
 Finishes: Dark Oak melamine; lacquers Hemp and Fuchsia.

Armoire battante avec côté latéral ép. 50; boiserie verticale à angle avec panneaux et miroirs équipée avec étagères, éléments hauts de rangement et porte-manteaux; élément bas avec tiroirs en appui sur banc ép. 50; Lit textile **Less**.
 Finitions: mélaminé Chêne Rouvre foncé; laqués Chanvre et Fuchsia.

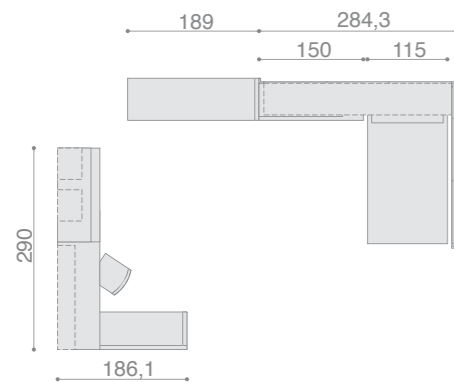

Piano di lavoro sp. 50 con panca porta contenitori in appoggio su Madia; contenitori pensili apertura push; mensole sp. 50; poltroncina imbottita.

50 mm thick desk, low shelf with cabinets; Suspended cabinets with push opening; 50 mm thick shelves; padded chair.

Plan de travail ép. 50 avec banc porte éléments de rangement en appui sur Huche: éléments hauts de rangement ouverture push; étagères ép. 50; fauteuil rembourré.







02 STARTLETTI



Monolocale arredato con Armadio **Duo**, cabina a giorno con ripiani, appendiabiti e contenitori pensili; libreria bifacciale con fianchi di chiusura sp. 50; piano di lavoro sp.50 in appoggio su basi contenitore con casettoni; casellario **Multiplo** e contenitori pensili apertura a ribalta; Letto tessile **Less** con testiera; comodino su panca sp. 50 e mensola sp. 50; poltroncina imbottita.
Finiture: melaminico Bianco; laccato Ocra, antracite.

One-room flat with **Duo** wardrobe, open walk-in wardrobe with shelves, hanging rails and suspended cabinets; double-sided bookcase with 50 mm thick closing sides; 50 mm thick desk mounted on base cabinets with deep drawers; **Multiplo** shelving unit and suspended cabinets with flap doors; **Less** bed with fabric cover, with headboard; bedside table mounted on a 50 mm thick low shelf, 50 mm thick shelves; padded chair.
Finishes: White melamine; lacquers Ochre, Anthracite.

Studio meublé avec: armoire **Duo**, cabine ouverte avec étagères, portemanteaux et éléments hauts de rangement, bibliothèque biface avec côtés de fermeture ép. 50; Plan de travail ép. 50 en appui sur éléments bas éléments de rangement avec grands tiroirs, casier **Multiplo** et éléments hauts de rangement ouverture relevable. Lit textile **Less** avec tête: table de nuit sur banc ép. 50; fauteuil rembourré.
Finitions: mélaminé Blanc; laqués Ocra, Anthracite.

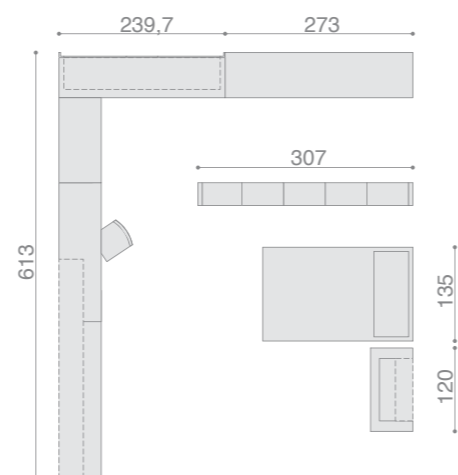





Monolocale arredato con : Armadio scorrevole **Duo** con pannelli e vetri laccati; Libreria con scrittoio sp. 50; letto **Pliè** ad un piazza e mezza; comodino su panca sp. 50; casellario **Cross**.
 Finiture; melaminico Bianco e Frasinio; laccato Verde Bosco e Bianco Giglio per i vetri dell'armadio.

One-room flat with **Duo** wardrobe with sliding doors, with lacquered panels and glass panels; Bookcase with 50 mm thick desk; **Pliè** three quarter bed; Bedside table mounted on a 50 mm thick low shelf; **Cross** shelving unit.
 Finishes: Ashwood and White melamine; lacquers Wood Green, Lily White (wardrobe glass panels).

Studio meublé avec: armoire coulissante **Duo** avec avec panneaux et verres laqués; bibliothèque avec bureau ép. 50; lit **Pliè** à une place et demie; table de nuit sur banc ép. 50; casier **Cross**.
 Finitions: mélaminé Blanc and Frêne; laqués Vert Bois, Blanc lys pour les verres de l'armoire.

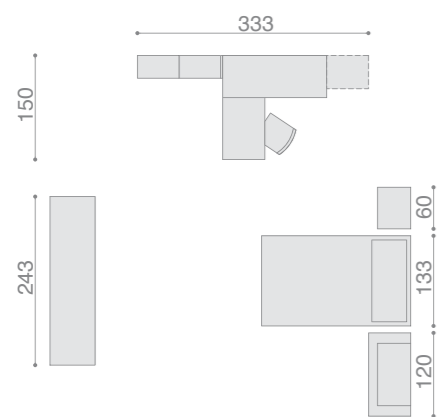







L'eleganza del design e l'accostamento cromatico si adattano perfettamente per una zona living all'interno della stanza.

Elegant design and a stunning combination of colours are perfect for a living area inside the room.

L'élégance du design et l'assemblage chromatique s'adaptent parfaitement à une zone living à l'intérieur de la pièce.





Monolocale arredato con: Armadio battente con ante **Stripes**; libreria con ante circolari; Letto Tessile **Doll** ad una piazza e mezza: comodino un cassetto; contenitori con cassettoni; contenitori pensili; casellario **Cross**.
Finitura: melaminico Bianco; laccato Canapa, Antracite.

One-room flat with wardrobe with hinged **Stripes** doors; bookcase with circular doors; **Doll** three quarter bed with fabric cover; bedside table with drawer; cabinets with deep drawers; suspended cabinets; **Cross** shelving unit.
Finish: White melamine; lacquers Hemp, Anthracite.

Studio meublé avec: armoire battante avec portes **Stripes**; bibliothèque avec portes circulaires; Lit Textile **Doll** à une place et demie table de nuit un tiroir; éléments de rangement avec grands tiroirs; éléments haut de rangement, casier **Cross**.
Finition: mélaminé Blanc; laqués Chanvre, Anthracite.

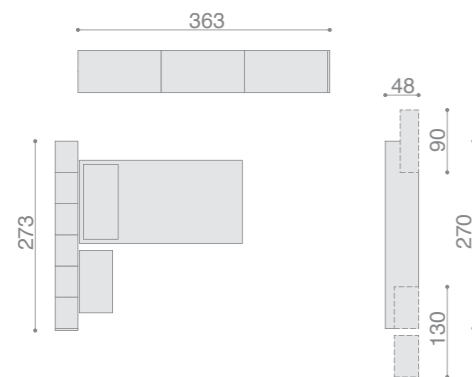





Armadiatura pensile; letto matrimoniale **Capitoné** in ecopelle con lavorazione capitoné; comodini due cassetti; libreria in appoggio su basi e piano di lavoro sp.50; settimanieri.

Finiture: melaminico Rovere Moro; laccato Canapa.

Suspended wardrobe; **Capitoné** double bed in tufted eco-leather; bedside tables with two drawers; bookcase mounted on base cabinets, 50mm thick desk; seven-drawer chests.

Finishes: Dark Oak melamine; lacquers Hemp.

Système d'armoire haute lit deux places **Capitoné** en écocuir avec travail capitonné; tables de nuit deux tiroirs; Bibliothèque en appui sur éléments bas et plan de travail ép. 50; semaineiers.

Finitions: mélaminé Chêne Rouvre foncé; laqués Chanvre.

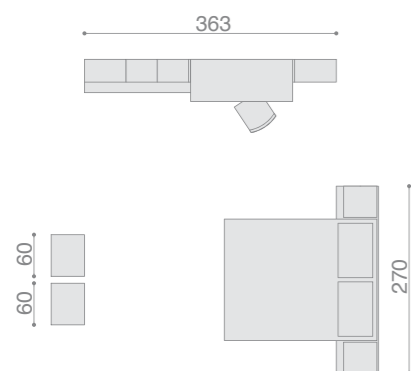





Armadio battente con fianco terminale sp. 50; piano di lavoro con cassettera; boiserie verticale con ripiani; pouf.
 Finiture: melaminico Bianco Rovere Moro.

Wardrobe with hinged doors with 50 mm thick finishing side; Desk with drawer cabinet; vertical boiserie with shelves; pouf.
 Finishes: Dark Oak, White.

Armoire battante avec côté de terminaison ép. 50; plan de travail avec meuble à tiroirs; boiserie verticale avec étagères; pouf.
 Finitions: Chêne rouvre foncé, Blanc.

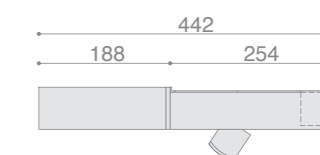

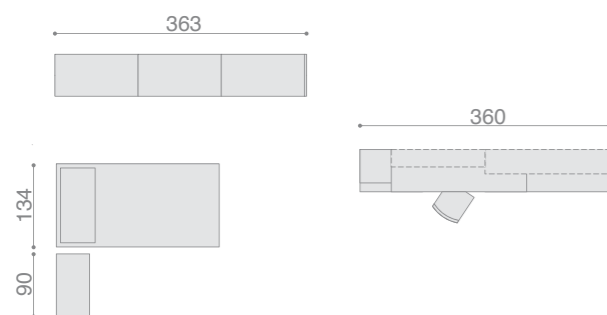

Armadio scorrevole anta Point con chiusura ammortizzata; letto **Less** in ecopelle; comodino un cassetto; piano di lavoro sp. 50 integrato con contenitori; elementi pensili con apertura a ribalta; mensola sp. 50; pouf ecopelle.
 Finiture: melaminico Bianco; laccato Bianco Giglio e Antracite.

Wardrobe with Point sliding doors with soft-closing mechanism; **Less** bed in eco-leather; bedside table with drawer; 50 mm thick built-in desk with cabinets; suspended cabinets with flap doors; 50 mm thick shelves; eco-leather pouf.
 Finishes: White melamine; lacquers Lily White and Anthracite.

Armoire coulissante porte Point avec fermeture amortie; lit **Less** en écocuir; table de nuit un tiroir; plan de travail ép. 50 intégré avec éléments de rangement; éléments hauts avec ouverture relevable; étagères ép. 50; pouf écocuir.
 Finition: mélaminé Blanc; laqués Blanc Lys et Anthracite.

03 BABYSTART

UNA CAMERETTA TUTTA DA ESPORARE | A BEDROOM TO BE EXPLORED | UNE CHAMBRE A EXPLORER COMPLETEMENT



BABY START CAMERETTE PER BAMBINI | CHILDREN'S BEDROOMS | CHAMBRES POUR ENFANTS



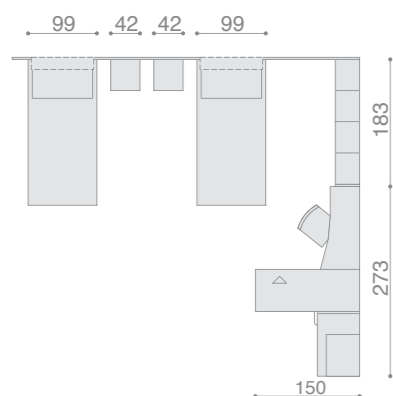

Letti **Snail**; libreria con scrittoio sagomato fisso e scrittoio, ribassato, scorrevoli; casellari **Wings**; contenitori **Round** su ruote; pannelli a muro di completamento; pouf.
 Finiture: melaminico Bianco; Flowers Ortensia; laccato Giallo Sole.

Snail beds; bookcase with fixed shaped desk and lower sliding desk; **Wings** shelving units; **Round** cabinets on wheels; finishing wall panels; pouf.
 Finishes: melamine White, Flowers Hydrangea; lacquers Sun Yellow.

Lits **Snail**; bibliothèque avec bureau façonné fixe et bureau, abaissé, coulissant; casiers **Wings**; éléments de rangement **Round** sur roues; panneaux muraux de complément; pouf.
 Finitions: mélaminé Blanc, Flowers Hortensia; laqués Jaune Soleil.









Armadio ad ante con maniglia **Tower**; letto **Nuvola**, testiera morbida; pannello retro letto; contenitore **Round** su ruote; casellario **Add**; Pouf.

Finiture: melaminico Bianco; laccato Miami e Giallo Sole.

Wardrobe doors with **Tower** handles; **Nuvola** bed, Soft headboard; panel behind bed; **Round** cabinet on wheels; **Add** shelving unit; Pouf.

Finishes: White melamine; lacquers Miami and Sun Yellow.

Armoire portes avec poignées **Tower**; lit **Nuvola**, tête douce; panneau arrière lit éléments de rangement **Round** sur roues; casier **Add**; Pouf.

Finitions: mélaminé Blanc; laqués Miami et jaune soleil.

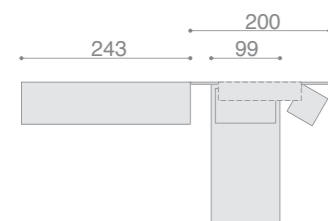

Particolare in cui si nota la morbidezza ed elasticità della Testiera **Nuvola**, realizzata in materiale ecocompatibile e innocua per la salute del bambino. La robustezza è garantita da un telaio in metallo annegato nella testiera.

These details emphasize the soft, elastic nature of the **Nuvola** headboard, which is made with environment-friendly materials that are harmless for your child. Sturdiness is guaranteed by the built-in metal frame of the headboard.

Détail sur lequel on remarque la douceur et l'élasticité de la tête **Nuvola**, réalisée en matériau éco-compatible et inoffensif pour la santé de l'enfant. La robustesse est garantie par un châssis en métal inséré dans la tête.



Armadio ante **Stripes**, letto **Nuvola**, testiera morbida; pannello retro letto; comodino due cassetti. Finiture: melaminico Bianco e Frassino; laccato Miami.

Wardrobe with **Stripes** doors, **Nuvola** bed, soft headboard; panel behind bed; bedside table with two drawers. Finishes: Ashwood and White melamine; Lacquers: Miami.

Armoire portes **Stripes**, lit **Nuvola**, tête souple; panneau arrière lit; table de nuit deux tiroirs. Finitions: mélaminé Blanc et Frêne; Laqués: Miami.





Letino **Castle**, per dormire comodamente e giocare: la scaletta può essere dotata di ruote che si bloccano con il peso del bambino garantendone la stabilità. Completano la sua stanzetta l'armadio con ante **Stripes**, la libreria ed i contenitori pensili e con ruote **Round**.

Finiture: melaminico Bianco; laccato Rosa e Giallo Sole.

Castle loft bed where to sleep comfortably and play. The ladder can be fitted with wheels that are locked in place when the child steps on it, for added stability. The bedroom is finished with a wardrobe with **Stripes** doors, a bookcase and **Round** cabinets, both suspended and with wheels.

Finishes: melamine White; lacquers Pink, Sun Yellow.

Lit superposé **Castle**, pour dormir confortablement et jouer: la petite échelle peut être dotée de roues qui se bloquent avec le poids de l'enfant en garantissant la stabilité. L'armoire avec portes **Stripes**, la bibliothèque et les éléments hauts de rangement avec roues **Round** complètent sa chambre.

Finitions: mélaminé Blanc; laqués Rose, Jaune soleil.

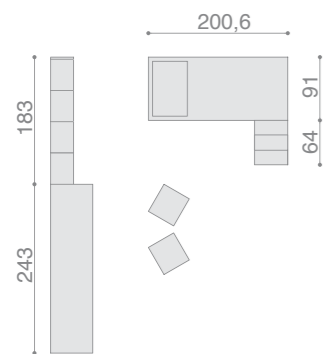







Armadio ad ante scorrevoli **Puzzle**; letto **Lully** con pannello retro letto; scrittoio regolabile in altezza **Growing**; contenitori pensili e con ruote **Round**.

Finiture: melaminico Bianco; Ante puzzle Flowers Calla inserto Flowers Orchidea, pannello retro letto flowers Orchidea; laccato Verde Mela.

Puzzle wardrobe with sliding doors; **Lully** bed with rear panel; **Growing** height-adjustable desk; **Round** cabinets, both suspended and with wheels.

Finishes: White melamine; Puzzle doors: Flowers Calla. Insert: Flowers Orchid, Panel behind bed: Flowers Orchid; lacquers Apple Green.

Armoire à portes coulissantes **Puzzle**; lit **Lully** avec panneau arrière lit bureau réglable en hauteur **Growing**; compartiments hauts et avec roues **Round**.

Finitions: Blanc, Portes puzzle Flowers. Calla empiècement Flowers Orchidée, panneau arrière-lit flowers Orchidée; laqués Vert Pomme.

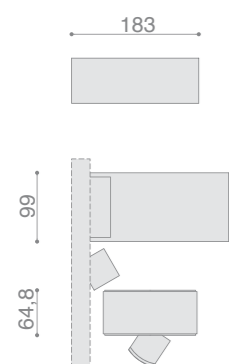

COLORE COME SEGNALE

IL COLORE È UN ELEMENTO DI GRANDE IMPORTANZA NELL'EQUILIBRIO GENERALE DELLA NATURA ED È UN MESSAGGIO CHE TESTIMONIA SEMPRE UNA SITUAZIONE PARTICOLARE.

IL COLORE, COME FORMA D'ENERGIA, È ATTIVO A TUTTI I LIVELLI DEL NOSTRO ESSERE FISICO, MENTALE, EMOZIONALE E SPIRITUALE.

I COLORI EMETTONO DELLE ONDE ELETTROMAGNETICHE CHE VENGONO ASSORBITE DAL CORPO UMANO E CHE LO INFLUENZANO SIA A LIVELLO FISICO CHE EMOTIVO. ED È GRAZIE A QUESTE ONDE CHE I NOSTRI OCCHI POSSONO VEDERE I COLORI; OGNI COLORE INFATTI HA DELLE ONDE DIVERSE.

ABITUAMOCI AD USARE ANCHE I COLORI PER RAGGIUNGERE UN GIUSTO STATO DI BENESSERE PSICO-FISICO.

IL COLORE È LA PRIMA COSA CON CUI VENIAMO A CONTATTO TRAMITE LA VISTA E TUTTI NOI NE SIAMO INFLUENZATI. I COLORI DELL'ARREDAMENTO, DELLE STANZE DELLA NOSTRA CASA, TUTTI QUESTI COLORI EVOCANO IN NOI DELLE EMOZIONI, DEGLI STATI D'ANIMO.

COLOUR AS A SIGN

COLOUR IS AN ELEMENT OF GREAT IMPORTANCE IN THE OVERALL EQUILIBRIUM OF NATURE; IT IS A MESSAGE THAT TESTIFIES TO A SPECIAL SITUATION.

COLOUR AS A FORM OF ENERGY IS ACTIVE AT ALL LEVELS OF OUR PHYSICAL, MENTAL, EMOTIONAL AND SPIRITUAL BEING.

COLOURS ISSUE ELECTRO-MAGNETIC WAVES THAT ARE ABSORBED BY THE HUMAN BODY AND INFLUENCE IT BOTH PHYSICALLY AND EMOTIONALLY. IT IS THESE WAVES THAT LET OUR EYES SEE COLOURS, EVERY ONE OF WHICH HAS DIFFERENT WAVES.

LET'S LEARN HOW TO USE COLOURS TO REACH THE RIGHT STATE OF PSYCHO-PHYSICAL WELLBEING. COLOUR IS THE FIRST THING WE COME INTO CONTACT WITH THROUGH SIGHT, AND IT INFLUENCES US ALL. COLOURS USED IN THE DECOR OF OUR HOMES AWAKEN EMOTIONS AND CREATE MOODS.

COULEUR COMME SIGNAL

LA COULEUR EST UN ÉLÉMENT DE GRANDE IMPORTANCE DANS L'ÉQUILIBRE GÉNÉRAL DE LA NATURE ET UN MESSAGÉ QUI TÉMOIGNE TOUJOURS UNE SITUATION PARTICULIÈRE.

LA COULEUR, COMME FORME D'ÉNERGIE, EST ACTIVE À TOUS LES NIVEAUX DE NOTRE ÊTRE PHYSIQUE, MENTAL, ÉMOTIONNEL ET SPIRITUEL.

LES COULEURS ÉMETTENT DES ONDES ÉLECTROMAGNÉTIQUES QUI SONT ABSORBÉES PAR LE CORPS HUMAIN ET QUI L'INFLUENCENT AUSSI BIEN AU NIVEAU PHYSIQUE QU'ÉMOTIF.

ET C'EST GRÂCE À CES ONDES QUE NOUS POUVONS VOIR LES COULEURS; CHAQUE COULEUR A EN EFFET DES ONDES DIFFÉRENTES. HABITUONS-NOUS À UTILISER ÉGALEMENT LES COULEURS POUR ATTEINDRE UN BON ÉTAT DE BIEN-ÊTRE PSYCHO-PHYSIQUE.

LA COULEUR EST LA PREMIÈRE CHOSE AVEC LAQUELLE NOUS ENTRONS EN CONTACT PAR LA VUE ET NOUS EN SOMMES TOUS INFLUENCÉS. LES COULEURS DE L'AMEUBLEMENT, DES PIÈCES, DE NOTRE MAISON, TOUTES CES COULEURS ÉVOQUENT EN NOUS DES ÉMOTIONS, DES ÉTATS D'ÂME.



FLOWERS



COLORE COME CLASSICITA'

SONO TUTTI QUEI COLORI CHE PARTONO DAL BIANCO PER CONTAMINARSI CON I COLORI NATURALI DELLE PIETRE E DELLE TERRE, E SONO LA BASE SULLA QUALE SI FONDA IL CROMATISMO DI START. TUTTI GLI ALTRI COLORI SONO USATI NELLA GIUSTA MISURA SIA PER IL LORO SIGNIFICATO SIA PER L'INFLUENZA SULLA PSICHE UMANA.

CLASSICAL COLOURS

ALL COLOURS STARTING FROM WHITE AND CONTAMINATED WITH THE NATURAL COLOURS OF STONE AND EARTH; THIS IS THE BASE FOR THE CHROMATIC EFFECT OF START. ALL OTHER COLOURS ARE USED IN THE RIGHT MEASURE ACCORDING TO THEIR MEANING AND PSYCHOLOGICAL INFLUENCE.

COULEUR COMME CLASSICISME.

CE SONT TOUTES LES COULEURS QUI PARTENT DU BLANC POUR SE CONTAMINER AVEC LES COULEURS NATURELLES DES PIERRES ET DES TERRES ET SONT LA BASE SUR LAQUELLE SE FOND LE CHROMATISME DE START. TOUTES LES AUTRES COULEURS SONT UTILISÉES DANS LA BONNE MESURE AUSSI BIEN EN RAISON DE LEUR SIGNIFICATION QUE DE LEUR INFLUENCE SUR LE PSYCHISME HUMAIN.

COLORE COME ELEGANZA

UNA GAMMA DI COLORI MATERICA, CARATTERIZZATA DA UNA SUPERFICIE PIACEVOLE AL TATTO E CAPACE DI CATTURARE LE VIBRAZIONI DELLA LUCE. FLOWERS TRAE ISPIRAZIONE DAI MATERIALI E DAI COLORI DELLA NATURA, CONIUGANDO BELLEZZA E FUNZIONALITÀ. OGNI COLORE RAPPRESENTA UN FIORE: LA CALLA, LA MIMOSA, IL GIRASOLE, L'ALOE, L'ORTENSIA E L'ORCHIDEA.

UNA GAMMA CROMATICA SPECIFICA DA ABBINARE ALLE ESSENZE O AI COLORI LACCATI.

ELEGANCE EXPRESSED IN COLOUR

THIS IS A RANGE OF TEXTURED COLOURS, FEATURING SURFACES PLEASANT TO TOUCH THAT CAPTURE THE LIGHT'S VIBRATIONS. FLOWERS IS INSPIRED BY NATURAL MATERIALS AND COLOURS THAT CREATE BEAUTY AND FUNCTIONALITY. EACH COLOUR REPRESENTS A FLOWER: ARUM LILY, MIMOSA, SUNFLOWER, ALOE, HORTENSIA AND ORCHID.

A SPECIFIC RANGE OF COLOURS TO MATCH WITH WOOD OR LACQUERED COLOURS.

COULEUR COMME ÉLÉGANCE

UNE GAMME DE COULEURS MATÉRIQUE, CARACTÉRISÉE PAR UNE SURFACE AGRÉABLE AU TOUCHER ET EN MESURE DE CAPTURER LES VIBRATIONS DE LA LUMIÈRE. FLOWERS PUISE

SON INSPIRATION DANS LES MATÉRIAUX ET DANS LES COULEURS DE LA NATURE, EN ALLIANT BEAUTÉ ET FONCTIONNALITÉ. CHAQUE COULEUR REPRÉSENTE UNE FLEUR: L'ARUM, LE MIMOSA, LE TOURNESOL, L'ALOE, L'ORTENSIA ET L'ORCHIDÉE.

UNE GAMME CHROMATIQUE SPÉCIFIQUE, À ASSEMBLER AUX ESSENCE OU AUX COULEURS LAQUÉES.

STARTSUMMARY

START



Start

P. 10



Start

P. 18



Start

P. 22



Start

P. 30



Start

P. 34



Start

P. 42



Start

P. 46



Start

P. 52



Start

P. 56



Start

P. 62



Start

P. 68



Start

P. 76



Start

P. 82



Start

P. 88



Start

P. 92



Start

P. 98



Start

P. 102



Start

P. 106



Start

P. 108



Start

P. 112



Start

P. 120



Start

P. 124



Start

P. 130



Start

P. 136



Start

P. 140



Start

P. 146



Start

P. 150



Start

P. 154



Start

P. 160



Start

P. 164



Start

P. 168



Start

P. 174

NIGHT&MORE



Night & More P. 180



Night & More P. 184



Night & More P. 186



Night & More P. 192



Night & More P. 196



Night & More P. 202



Night & More P. 208



Night & More P. 214



Night & More P. 216

BABYSTART



Baby P. 220



Baby P. 226



Baby P. 231



Baby P. 232



Baby P. 238



art direction studio Mazzer
graphix Lisa Longo
photo Link
styling Laura Pozzi / assistente Emanuele Vitaliano
colour separation Link
printed Grafiche Antiga

thanks to Moroso
 Fontanaarte
 Sphaus
 Paloma di Daniele Lorenzon
 Tou Tou di Laura Pozzi
 GB Ballardini
 Kasthall
 Artfabrica lafil
 Mauro Bolognesi
 Roberto Novaresi Haute couture
 Melissa shoes
 Poemo design
 Tisca
 Antonino Sciortino
 Danese Milano
 Dejavù home
 Roberto Barazzuol modernariato
 Ceramiche Milesi
 Altai
 Paola lenti
 Muji
 David Sorgato
 Gabriella Benetello modernariato
 Gabriella Pozzi- Magazzino raccolta
 ABC informatica

CLEVER

Clever s.p.a. - FACTORY
via G.Pascoli, 5/7/9
31053 Pieve di Soligo (Tv) Italy
tel. +39 0438 909011 - fax +39 0438 909090
e-mail: clever@homes.it - www.clever.homes.it

Export Department
ph. +39 0438 839832 - fax +39 0438 839859
e-mail: export@homes.it - www.homes.it

HOMES s.p.a. - HEADQUARTERS
via Montello - 31053 Pieve di Soligo (Tv) Italy
tel. +39 0438 909081 - fax +39 0438 909089
e-mail: info@homes.it - www.homes.it